



# Fundamentals of Vector Signal Analysis

Hiroshi Kikuyama  
*Verigy Japan*

## 1. Introduction

In RF/Microwave device testing that involves higher load board density, more complex impedance matching approaches need to be understood. Vector Network Analysis is one of the most effective methods of characterizing impedance matching.

The purpose of this article is to provide the test engineer with a fundamental understanding of vector network analysis. The article will start by describing the fundamentals of impedance, transmission lines, and loads. It will go on to describe common terms for RF/Microwave device characterization such as return loss, SWR (standing wave ratio), and S-parameters. Other RF fundamentals such as Error Correction and the Smith Chart will also be reviewed.

## 2. Impedance, Transmission Line and Load

In this section, fundamentals of impedance, loads, and transmission lines are described. First, the fundamentals of impedance are described via the three types of fundamental electrical circuit elements; Resistors, Capacitors, and Inductors. Then the fundamentals of loads are described using simple electric circuit diagrams. Finally, fundamentals of transmission lines are described.

### 2.1. Impedance

The symbol for electrical impedance is  $Z$ . If the circuit is driven with alternating current (AC), impedance has real and imaginary parts as in equation (1).

$$Z = R + jX$$






(1)

The real part of impedance is resistance  $R$ . Resistance is responsible for power dissipation and amplitude changes in signals. When impedance consists of purely resistance ( $Z = R$ ) there is no phase shift between the voltage and current. The imaginary part of impedance is reactance  $X$ , it induces a phase shift between the voltage and current. Table 1 shows how the impedance of the three types of fundamental passive electrical circuit elements is represented in an AC circuit.

A resistor consists of resistive materials, it simply impedes electron flow. This is why increasing resistance, while keeping the voltage across the resistor the same, will decrease current. A capacitor consists of parallel, conductive plates separated by dielectric material. In an AC circuit, it has purely reactive impedance which is inversely proportional to the signal frequency. A capacitor's plates will alternately fill up and become empty (discharge). Electrons will continue to flow. As a result a capacitor has nearly infinite impedance (like an open circuit) at low frequencies and a capacitor has very little impedance (like a short circuit) at higher frequencies. If the circuit is driven with DC, a capacitor will act like an

open circuit. An inductor consists of coiled conductor with low resistive material. In an AC circuit, it has nearly a purely reactive impedance which is proportional to the signal frequency. If the circuit is driven with DC, an inductor will act like a short circuit.

**Table 1: Impedance of passive electrical circuit elements in an AC circuit**

	Impedance (Z)
Resistor 	$R$
Capacitor 	$-1/j\omega C$
Inductor 	$j\omega L$
	$R + j(\omega L - 1/\omega C)$
	$(R + j\omega L)/(j\omega CR + (1 - \omega^2 LC))$

R : Ohm  
 C : Farad  
 L : Henry  
 $\omega$  : represents frequency in radians/second  
 $j = \sqrt{-1}$  (90° phase shift)

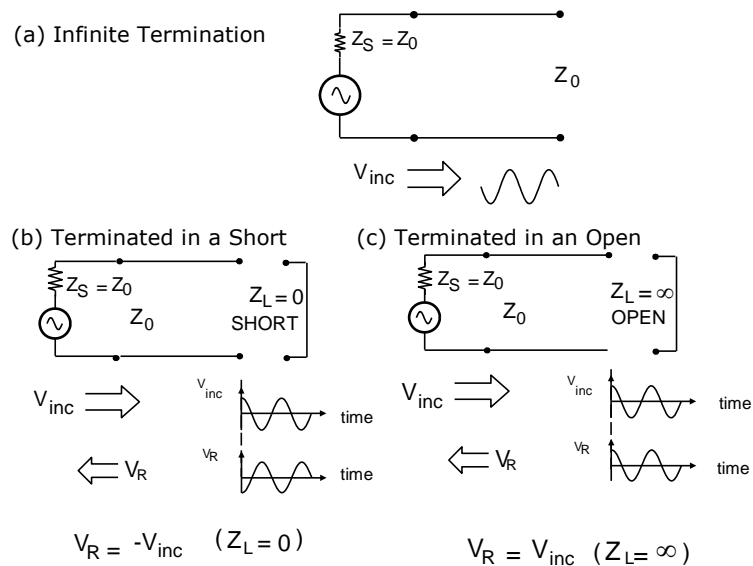
## 2.2. Transmission Line and Load

An electrical load can be viewed as an output device in electrical circuits. It uses the energy from the power source, thus, it affects the performance of electrical circuits that output voltage and current. If we send signals down an infinite length of transmission line, nothing will happen since the signal can't distinguish a between load impedance  $Z_0$  and an infinite length of line (Figure 1 (a)). If we send a signal into a short circuit, a reflected signal wave is launched back on the line because a short circuit cannot sustain voltage and there is nowhere else for energy to go. For Ohm's law to be satisfied (no voltage at the short) this reflected voltage  $V_R$  wave must have a magnitude equal to the incident voltage wave  $V_{inc}$ . Also, the reflected voltage wave  $V_R$  must be 180 degrees out of phase with the incident voltage wave  $V_{inc}$  (Figure 1 (b)). If we send a signal down into an open circuit, a reflected voltage wave  $V_R$  which has an amplitude equal to the incident voltage wave  $V_{inc}$  is launched back the line like a short circuit. However, the reflected voltage wave  $V_R$  will be in phase with the incident voltage wave  $V_{inc}$ . For Ohm's law to be satisfied, there can be no current at the open and reflected and incident current waves will be identical but traveling in the opposite direction, thus, the voltage waves will be in phase (Figure 1 (c)).

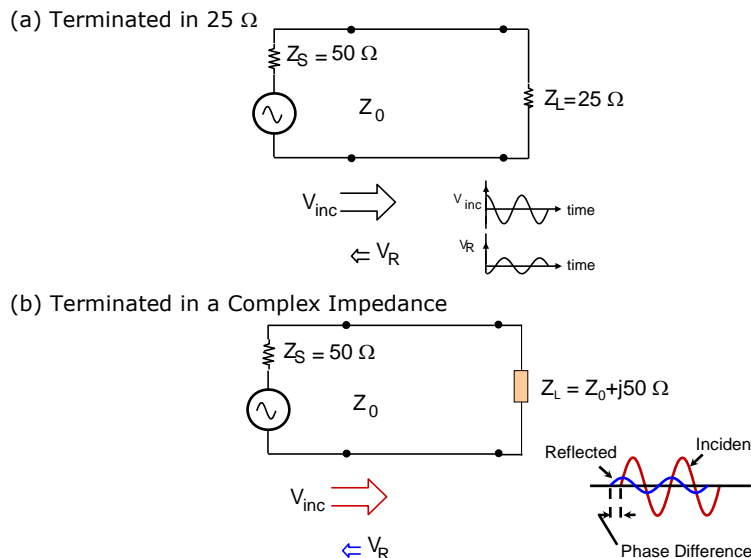
If we terminate transmission line with  $25\Omega$  load, the reflected voltage wave  $V_R$  will have an amplitude 1/3 of that of the incident voltage wave,  $V_{inc}$ , since the reflection coefficient  $\Gamma$  is given by equation (2), and the two voltage waves will be 180 degrees out of phase (Figure 2 (a)). (Details of the reflection coefficient  $\Gamma$  will be described in the next Section.)

$$\Gamma = \frac{Z_L - Z_0}{Z_L + Z_0} = \frac{25\Omega - 50\Omega}{25\Omega + 50\Omega} = -\frac{25\Omega}{75\Omega} = -\frac{1}{3} \quad (2)$$

When a transmission line is terminated in a complex impedance, the most common scenario, the reflected voltage wave will have a different magnitude and phase than the incident voltage wave (Figure 2 (b)).

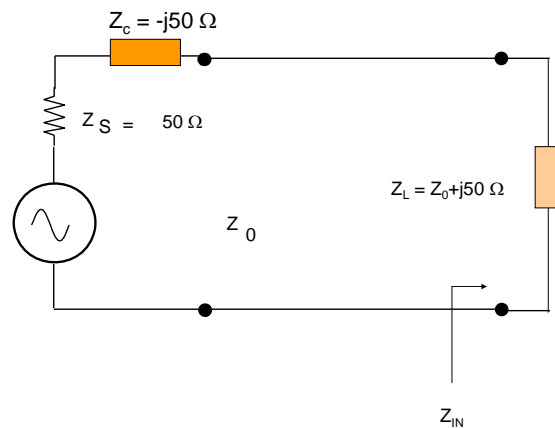


**Figure 1: Transmission Line Terminated in Short and Open**



**Figure 2: Transmission Line Terminated in  $25\Omega$  Load and Complex Impedance**

For instance, if a transmission line is terminated in a complex impedance  $Z_L (=Z_0+j50)$ , a load  $Z_C (= -j50)$  will be required as in Figure 3. This  $Z_C$  will allow a transmission line to be terminated in the complex conjugate of the input impedance. As a result, we will be able to get maximum power transfer from the source and minimum reflection from the load. This is the ultimate objective of impedance matching.



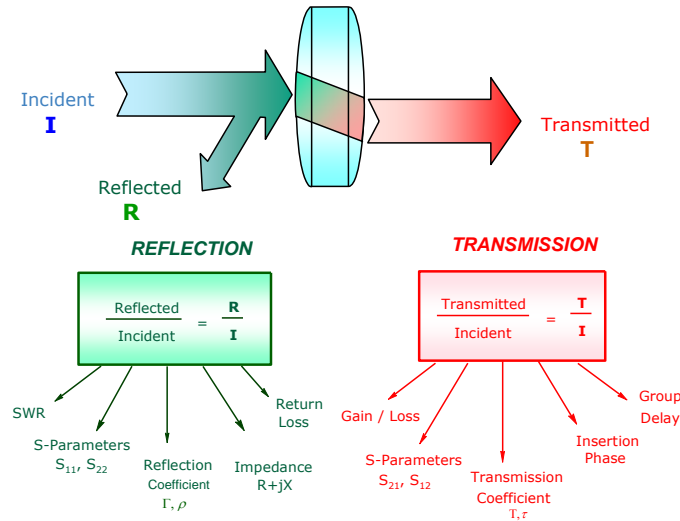
**Figure 3: Transmission Line with Complex Input Impedance**

### 3. Fundamentals of Transmission and Reflection

In this section, fundamentals of transmission/reflection and some important terms for RF/Microwave device characterization are described. First, fundamentals of transmission and reflection are described using the lightwave analogy. Next, reflection parameters, especially, Return Loss and SWR (Standing Wave Ratio) are described. Then, transmission parameters are described.

#### 3.1. Transmission and Reflection – Lightwave Analogy

Using the concepts of lightwave as an analogy will make the understanding the network analysis easier. When a lightwave strikes a clear lens, some of the light is reflected from the lens surface, but most of it continues to through the lens (Figure 4). We can apply the same principal to RF and microwave signals. For instance, the energy of a RF/microwave signal that is launched on to a transmission line will be similar to the incident wave I. The portion that is reflected back down the transmission line toward the source due to impedance mismatch will be similar to the reflected wave R, and successfully transmitted to the terminating device will be similar to the transmitted wave T. We can characterize several important parameters such as Reflection/Transmission Coefficient, Return Loss, SWR(Standing Wave Ratio), S-Parameters ( $S_{11}$ ,  $S_{12}$ ,  $S_{21}$ ,  $S_{22}$ ), Impedance, and Gain/Loss by measuring the magnitude and phase of the incident, reflected, and transmitted RF/microwave signal.



**Figure 4: Transmission and Reflection – Light and Wave Analogy [2][6]**

### 3.2. Reflection Parameters - Return Loss and SWR (Standing Wave Ratio)

The reflection coefficient  $\Gamma$  is the essential term for understanding Return Loss. It is the ratio of the reflected signal voltage level ( $V_R$ ) to the incident signal voltage level ( $V_{INC}$ ), given by equation (3).

$$\Gamma = \frac{V_R}{V_{INC}} = \frac{Z_L - Z_0}{Z_L + Z_0} \quad (3)$$

Rho ( $\rho$ ) is the magnitude of the reflection coefficient, it is given by equation (4).

$$\rho = |\Gamma| \quad (4)$$

If  $Z_L$  is equal to  $Z_0$ , all signal energy will be transferred to the load,  $V_R = 0$  and  $\rho = 0$ . If  $Z_L$  is not equal to  $Z_0$ , some signal energy will be reflected by the load and  $\rho$  will be greater than zero. If  $Z_L =$  a short or open circuit, all energy will be reflected by the load, and  $\rho = 1$ . The range of possible values for  $\rho$  is 0 to 1. Return Loss (RL) is a way to express the reflection coefficient in logarithmic terms (decibels: dB) and it is given by equation (5).

$$\text{Return Loss (dB)} = -20 \log \rho \quad (5)$$

For instance, when the magnitude of incident signal is 1.0V and the magnitude of reflected signal is 0.5V, then  $\rho = 0.5$  as equation (6).

$$\rho = \left| \frac{V_R}{V_{INC}} \right| = \left| \frac{0.5}{1.0} \right| = 0.5$$

(6)

As a result, Return Loss will be 6dB as equation (7)

$$\text{Return Loss (dB)} = -20 \log(0.5) = 6 \quad (7)$$

Return Loss is always expressed as a positive number and varies between infinity for Zo impedance and 0 dB for an open or short circuit.

Any two waves traveling in opposite directions on the same media will cause a "standing wave". Consequently, the last reflection term is standing wave ratio (SWR), and it is defined as the maximum voltage over the minimum voltage on our transmission line. Mathematically, it can also be defined as equation (8).

$$SWR = \frac{1 + \rho}{1 - \rho}$$

(8)

Since  $\rho$  can take on values of 0 to 1, SWR can take on values of 1 to infinity.

### 3.3. Transmission Parameters – Insertion Loss, Gain, and Group Delay

Transmission Coefficient, T, is defined as the transmitted voltage divided by the incident voltage as equation (9). If  $|V_{transmitted}| > |V_{incident}|$ , it means the DUT has gain. Gain is given by equation (10). If  $|V_{transmitted}| < |V_{incident}|$ , it means the DUT exhibits attenuation or Insertion Loss. Insertion Loss is given by equation (11).

The phase portion of the transmission coefficient is called insertion phase.

$$T = \frac{V_{transmitted}}{V_{incident}} = \tau \angle \phi \quad (9)$$

$$Gain(dB) = 20 \log \left| \frac{V_{transmitted}}{V_{incident}} \right| \quad (10)$$

$$Insertion Loss(dB) = -20 \log \left| \frac{V_{transmitted}}{V_{incident}} \right|$$

(11)

## 4. S-Parameters, Error Correction, and Smith Chart

In this section, Other RF fundamentals such as the S-Parameters, network analyzer architecture, Error Correction, and Smith Chart are described. Fundamentals of S-Parameters are described in first two sub sections. Next, vector network analyzer architecture is described. Then, fundamentals of Error Correction are described. Fundamentals of Smith Chart are described in final sub section.

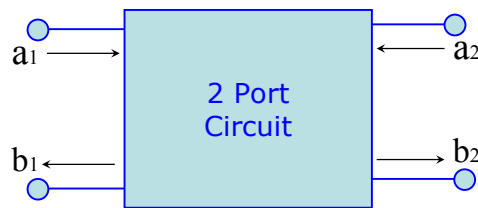
### 4.1. S-Parameters

At RF/Microwave area, it is very hard to measure total voltage and current at the device ports due to the difficulties of connection between device ports and measurement equipments. Impedance of the probes themselves and the difficulty of placing the probes at the desired positions prevent us from getting accurate measurements. In addition, active devices such as Power Amplifiers may oscillate or self-destruct with the connection of shorts and opens. To characterize RF/Microwave networks, other way was required without these drawbacks. This is why S-parameters were developed. S-parameters are defined in terms of incident and reflected voltage traveling waves, which are relatively easy to measure compare to total voltage and current measurement. Also, S parameters have several

advantages compare to other traditional parameters such as H, Y, and Z parameters as followings.

- The connection of undesirable loads to DUT(device under test) is not required,
- S-parameters of multiple devices can be cascaded to predict overall system performance.
- S-parameters are easily imported and used for circuit simulations in EDA (Electronic Design Automation) tools.

An N-port device has  $N^2$  S-parameters. Thus, if the device has two ports, its device has four S-parameters. The first number following the "S" is the port where the signal emerges, and the second number is the port where the signal is applied. Thus, S21 means a measure of the signal coming out port 2 relative to the RF stimulus entering port 1. When the numbers are the same (e.g., S11), it means a reflection measurement, as the input and output ports are the same. The incident terms ( $a_1$ ,  $a_2$ ) and output terms ( $b_1$ ,  $b_2$ ) represent voltage traveling waves, as a result, two-port S-parameters will be defined as Figure 5.



$$b_1 = S_{11} a_1 + S_{12} a_2$$

$$b_2 = S_{21} a_1 + S_{22} a_2$$

**Figure 5: S-Parameter Definition (2 port device)**

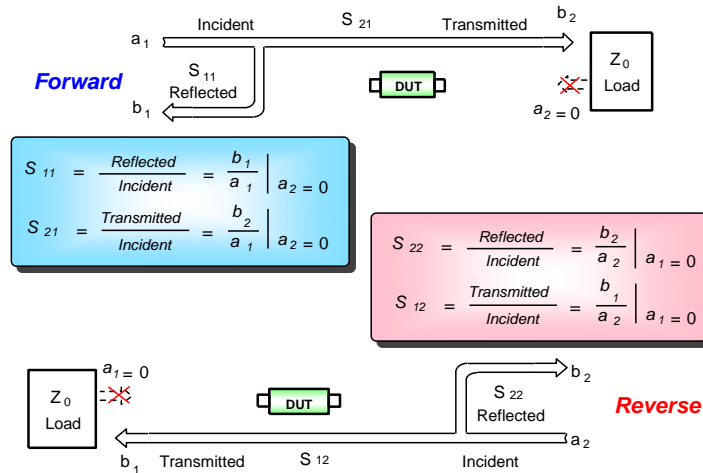
#### 4.2. Measuring Two-port S-Parameters

Figure 6 shows the principle of two-port S-parameter measurement.

S11 and S21 are determined by measuring the magnitude and phase of the incident, reflected, and transmitted voltage signals when the output is terminated in a perfect  $Z_0$ . A perfect  $Z_0$  means an ideal load that equals the characteristic impedance of the test system,

this condition guarantees  $a_2 = 0$  because of no reflection from an ideal load.

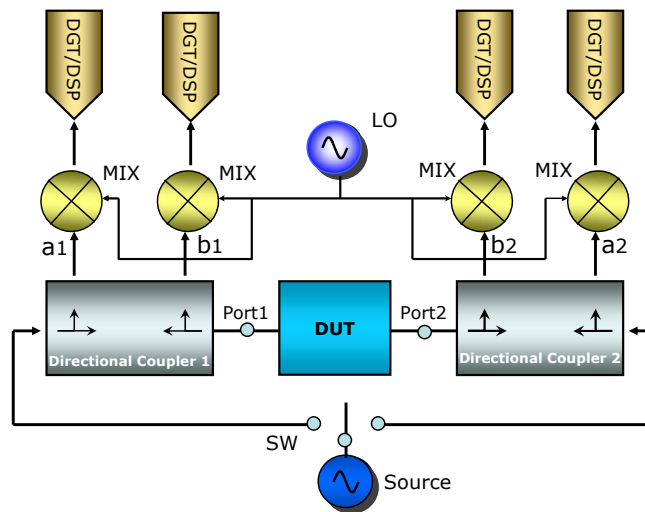
S11 is equivalent to the input complex reflection coefficient or impedance of the DUT, and S21 is the forward complex transmission coefficient. Likewise, by placing the source at port 2 and terminating port 1 in a perfect load to make  $a_1$  zero, S22 and S12 measurements can be performed. S22 is equivalent to the output complex reflection coefficient or output impedance of the DUT, and S12 is the reverse complex transmission coefficient. The accuracy of S-parameter measurements depends greatly on how good a termination we apply to the port not being stimulated. Anything other than a perfect load will result in  $a_1$  or  $a_2$  not being zero since which violates the definition for S-parameters. [2][4][5]



**Figure 6: 2port S-Parameter Measurement [2][6]**

### 4.3. Network Analyzer Architecture

A vector network analyzer can measure S-parameters as complex number  $R+jX$ , including magnitude and phase information of RF/Microwave signal. Figure 7 shows a generalized block diagram of a vector network analyzer, showing the major signal-processing sections. Usually, a vector network analyzer has heterodyne receiver architecture which enables wider frequency bandwidth and dynamic range. Thus, most vector network analyzers have two separate sources, generally which are frequency synthesizers, one is the Source for stimulus to DUT and the other is LO (system local source) for down conversion. Incident RF/Microwave signal  $a_1$  and reflected RF/Microwave signal  $b_1$  from port1 are separated by the Directional Coupler 1, Likewise, incident RF/Microwave signal  $a_2$  and reflected RF/Microwave signal  $b_2$  from port2 are separated by the Directional Coupler 2. These separated RF/Microwave signals are down-converted to IF (intermediate frequency) signals in the MIX (mixer). Down-converted IF signals are captured by the Digitizer/DSP units. Finally, analog-to-digital conversion and DSP (digital-signal processing) are performed in the DGT/DSP units, magnitude and phase information are extracted from IF signals.



### Figure 7: Generalized Block Diagram of Vector Network Analyzer

On the other hand, a scalar network analyzer can only measure S-parameters as absolute value, phase information of RF/Microwave signal is lost. Thus, diode detectors can be used for IF signal detection, it enables inexpensive system cost compare to a vector network analyzer.

#### 4.4. Error Correction

There are three basic sources of measurement error, systematic errors, random errors, and drift errors. Systematic errors can be removed by calibration, since Systematic errors are caused by imperfections in the analyzer and test setup and they are repeatable, predictable, and time invariant. Random errors cannot be removed by calibration since they vary with time in random fashion and are unpredictable. The instrument noise, such as source phase noise, sampler noise, and IF noise are main contributors to random errors. Drift errors can be removed by further calibration(s), since these errors are caused by the instrument or test-system performance changing after a calibration has been done.

Figure 8 shows the full two-port error model, all systematic errors associated with 2-port network measurements. The full two-port error model includes all six of these terms for the forward direction and the same six (with different data) in the reverse direction, for a total of twelve error terms. The errors relating to signal leakage  $E_D$ ,  $E_{D'}$ ,  $E_X$ , and  $E_{X'}$ , these error terms are called directivity and isolation. The errors related to signal reflections  $E_S$ ,  $E_{S'}$ ,  $E_L$ , and  $E_{L'}$ , these error terms are called source and load match. The final class of errors are related to frequency response of the receivers  $E_{RT}$ ,  $E_{RT'}$ ,  $E_{TT}$ , and  $E_{TT'}$ , and these error terms are called reflection and transmission tracking.

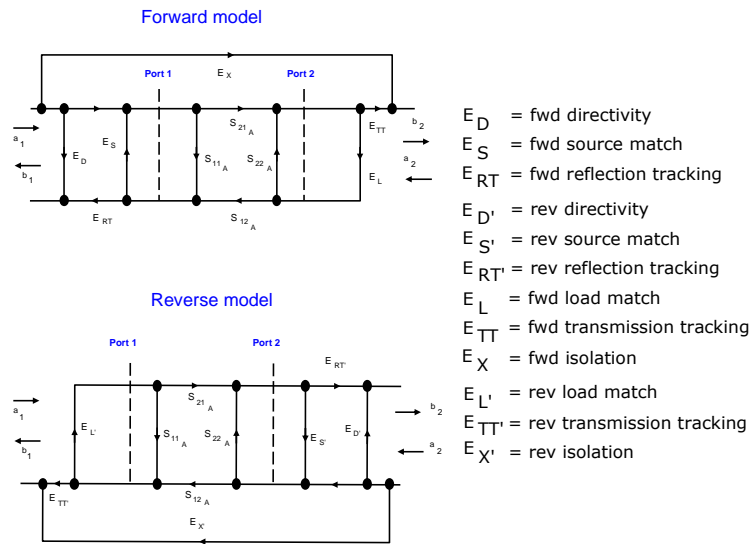


Figure 8: Full two-port Error Model [2]

There are the two main types of error corrections, one is a response (normalization) correction and the other is a vector correction. Table 2 shows pros and cons between these two error correction types. Response correction has two major advantages. It is simple to perform, and low-end analyzers with diode signal detection can be used. It also has some disadvantages, it only corrects for the tracking errors, phase errors can not be corrected. Thus, measurement accuracy is inferior as compared with a vector correction. On the other hand, a vector correction stands on an opposite position. It can account for all the major sources of systematic error, thus, very accurate measurements become available.

Since magnitude and phase data are necessary for a vector correction, a vector network analyzer and more calibration standards are required. By measuring known calibration standards, vector correction can remove the effects of these systematic errors. Usually, one-port calibration can be used for reflection measurements, it can measure and remove three systematic error terms, directivity, source match, and reflection tracking. Full two-port calibration can be used for both reflection and transmission measurements, and all twelve systematic error terms are measured and removed. Thus, it usually requires twelve measurements on four known standards (short-open-load-through: SOLT), and some standards are needed to measure multiple times.

**Table 2: Types of Error Correction – Pros and Cons**

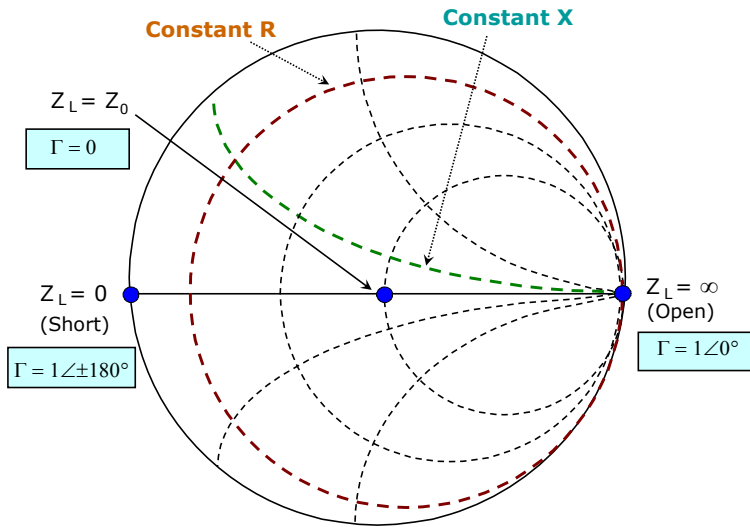
	Response Correction	Vector Correction
Pros	<ul style="list-style-type: none"> <li>• Simple to perform</li> <li>• Can use low-end analyzers using diode signal detection</li> </ul>	<ul style="list-style-type: none"> <li>• Accounts for all major sources of systematic error</li> <li>• Gives very accurate measurements</li> </ul>
Cons	<ul style="list-style-type: none"> <li>• Only corrects for the tracking errors</li> <li>• No phase error correction</li> <li>• Less measurement accuracy</li> </ul>	<ul style="list-style-type: none"> <li>• Requires more calibration standards</li> <li>• Requires analyzers that can measure phase</li> </ul>

#### 4.5. Smith Chart

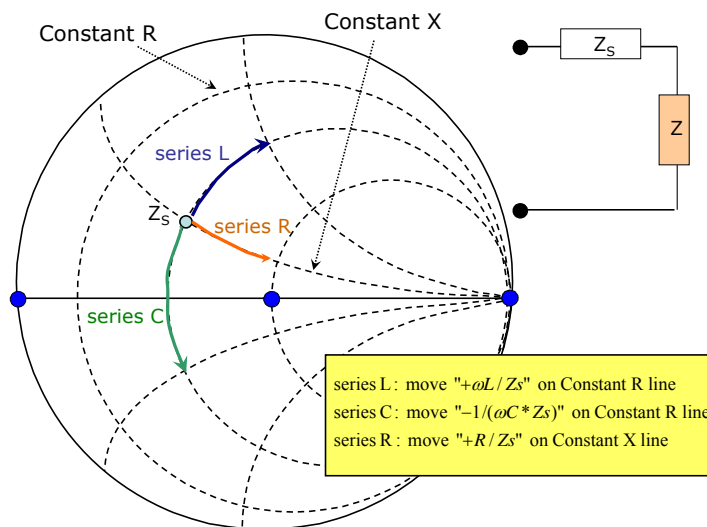
Network analysis gives us the complex reflection coefficient. However, we often want to know the impedance of the DUT. We can manually perform the complex math to find the impedance from the relationship between reflection coefficient and impedance as shown in Figure 5. Although computers take the drudgery out of doing the math, a single number does not always give us the complete picture. In addition, impedance changes with frequency, so even if we did all the mathematical post processes, we would end up with a table of numbers that may be difficult to interpret. In the 1930's, Phillip H. Smith created the proper solution. He mapped the impedance plane onto the polar plane, creating the chart that bears his name. Figure 9 shows a Smith Chart (impedance chart). In general, Smith charts are normalized to  $Z_0$ ; that is, the impedance values are divided by  $Z_0$ . Actual impedance values are derived by multiplying the indicated value by  $Z_0$ . For instance, in a 50-ohm system, a normalized value of  $0.4 - j0.25$  becomes  $20 - j12.5$  ohms; in a 75-ohm system,  $30.0 - j18.75$  ohms. [2][6]

Figure 10 shows how impedance moves on the Smith Chart.

For instance, if the original load impedance is  $Z_s$  and an inductor  $L$  is series-connected with  $Z_s$ , then the impedance will move  $+j\omega L / Z_s$  on the constant resistance line (circle). If the capacitor  $C$  is series-connected with  $Z_s$ , then the impedance will move  $-j/(\omega C * Z_s)$  on the constant resistance line. If the resistor  $R$  is series-connected with  $Z_s$ , then the impedance will move  $+R / Z_s$  on the constant reactance line (arc).



**Figure 9: Smith Chart**



**Figure 10: Impedance trajectory trends on the Smith Chart**

## 5. Conclusion

The fundamentals of Vector Signal Analysis have been described. Some of them are well-known terms for expert engineers. However, understanding these fundamentals more correctly and deeper is also the first important step for characterizing impedance matching more effectively.

## 6. Acknowledgements

The author would like to thank his colleagues, Joe Kelly, Edwin Lowery and Oscar Solano for their suggestions and technical feedback.

## 7. References

- [1] Connor. F.R., "*Networks*", Edward Arnold, Second Edition, 1986
- [2] Ballo. D. , "*Network Analyzer Basics*", Hewlett-Packard Company,1998
- [3] Razavi. B., "*RF Microelectronics*", Prentice Hall, 1998
- [4] Aikawa. M. ,Ohira.T, et al, "*Monolithic Microwave Integrated Circuit*", IEICE, Tokyo, 1997
- [5] Itoh. Y., and Takagi. T, "*Fundamentals and Applications of MMIC Technologies*", Realize, Tokyo, 1996
- [6] "Understanding the Fundamental Principles of Vector Network Analysis", Agilent Technologies, Application Note 1287-1
- [7] "Exploring the Architectures of Network Analyzers", Agilent Technologies, Application Note 1287-2

## Copyright

Verigy owns the copyrights of all submitted papers/articles.